

# Deep Life Open Revolution Product: Commercial Diving Rebreather DESIGN VERIFICATION REPORT: SAFETY OF UMBILICAL TERMINATOR POWER SYSTEMS UNDER FAULT CONDITIONS

DOCUMENT NUMBER: DV\_Umbilical\_Terminator\_PSUs\_A3r\_080422.doc  
 [Filename]  
 Design Authority: Vladimir Vikulin to 2008, then Igor Abrosimov  
 Verification Team: Dr. S. Pyko, M. Evtukov, Dr. A. Deas, P. Kamochkin  
 DEPARTMENT: Engineering  
 LAST UPDATED: 22<sup>nd</sup> April 2008  
 REVISION: A3r

<b>APPROVALS</b>	
_____ Hardware Architect	_____ Date
_____ Software Architect	_____ Date
_____ Project Manager	_____ Date
_____ Quality Officer	_____ Date

Controlled Document     Classified Document      
**DO NOT COPY IF MARKED**

Copyright © Deep Life Ltd, 2008

All information and data provided herein are for general information purposes only  
and are subject to change without notice or obligation.

**Revision History**

<b>Revision</b>	<b>Date</b>	<b>Description</b>
A	17-03-2008	Initial document.
A1	21-03-2008	External power supply validation description added..
A2	26-03-2008	Reviewed and released.
A3	29-03-2008	“For information” section added to page 8. “Scrubber heater” corrected to “Counterlung heater” throughout the document.
A3r	22-04-2008	Review updates implemented. Separated from SVN and approved for release.

# TABLE OF CONTENTS

**TABLE OF CONTENTS**..... 3

**1 PURPOSE AND SCOPE** ..... 5

**2 SCOPE**..... 5

**3 SIL ASSESSMENT AND SAFETY ARCHITECTURE** ..... 5

3.1 Safety Integrity Level Assessment.....5

3.2 Safety Architecture.....5

**4 ABBREVIATIONS**..... 5

**5 POWER TREE** ..... 6

**6 POWER SOURCE CHARACTERISTICS** ..... 7

**7 POWER ARCHITECTURE REVIEW** ..... 8

7.1 Internal UT power, BASE and PFD power supplies .....8

7.2 UT power sources for heaters, lamps and cameras .....8

7.3 Engineering Change Order (ECO) Rework list.....9

**8 EQUIPMENT USED FOR EMPIRICAL TESTING** ..... 9

**9 VALIDATION TESTS**..... 10

9.1 Status on power up .....10

9.2 Validate PSUs across the spectrum of normal load conditions.....11

9.3 Absence of Overshoot.....12

9.4 Internal power supplies and BASE power supplies (power1, power2) validation .....13

9.5 PSU validation under single supply fault conditions .....14

9.6 Simultaneous short circuits.....14

9.6.1 Simultaneous short circuits (power-to-ground) on all power supplies.....14

9.6.2 Output to output short circuit tests.....16

9.7 Salt water shorts .....17

**9.8 Worst case thermal faults.....19**  
    9.8.1 Hazard level.....19  
    9.8.2 Limits.....19

**9.9 Result summary .....20**

**10 CONCLUSION ..... 20**

# 1 PURPOSE AND SCOPE

The purpose of this document is to verify the function of the Umbilical Terminator (UT) power supplies under fault conditions. This is a Design Verification document covering all of the power supplies into and out of the Umbilical Terminator (UT) that provides all rebreather telemetry, voice and video comms between the diver and the top side. It also powers the divers lights, cameras, suit heaters, counterlung heaters and rebreather.

The UT is contained in its own silicone oil filled chamber, separate from the rebreather.

The UT was referred to as a MUX prior to the safety review and design review for production support in Q4 2007, where it was felt it could be confused with the microMUX and the description was technically inaccurate – it is far more than a multiplexer.

## 2 SCOPE

This document is concerned with the consequences of failures, through short circuits of outputs, flooding of connectors and failure of umbilical supplies, based on UT Circuit Diagram Revision C1.

The UT on-board power supplies are described and analysed from over-current protection point of view. A number of recommendations (reworks) are produced based on the analysis. Empirical tests were carried out to verify that the actions concluded have the desired intent and are effective, and the results of those tests are described.

## 3 SIL ASSESSMENT AND SAFETY ARCHITECTURE

### 3.1 Safety Integrity Level Assessment

The UT has been assessed as SIL 2.

### 3.2 Safety Architecture

The architecture of the UT is described in detail in a Green Book Specification, and the architecture has been reviewed on a Devil's Advocate basis by an independent reviewer: a report of October 2007 was issued by I. Abrosimov. The present architecture is deemed suitable for SIL 3.

The UT is a dual redundant system, using two umbilical power sources of which only one needs to be present. All logic is divided between two large FPGAs and associated hard logic: there is no micro-controller (MCU) other than that in the USB interface chip, as a MCU would be difficult to pass safety assessment at this level. The rebreather does not power the UT, except for a bypass through to the PFD: the PFD is connected to the UT instead of to the rebreather. The rebreather has quad redundant power.

A full programmed model of the UT exists for verification purposes. The design itself is executed in Verilog and verified in the same manner as for custom ASICs.

The FPGA contents and the board operation has been verified in a structured manner and Design Verification report exists. The USB port is not used when the rebreather is operating: it is for diagnostics only.

An independent total review was carried out of the design, and a report issued. This did identify an undue overhead in supporting the UT in volume production, and rectification actions were implemented. The power supplies in both C1 and D revisions of the UT are identical other than minor circuit clean-up items.

## 4 ABBREVIATIONS

- ◆ FPGA Field Programmable Gate Array.

# 5 POWER TREE

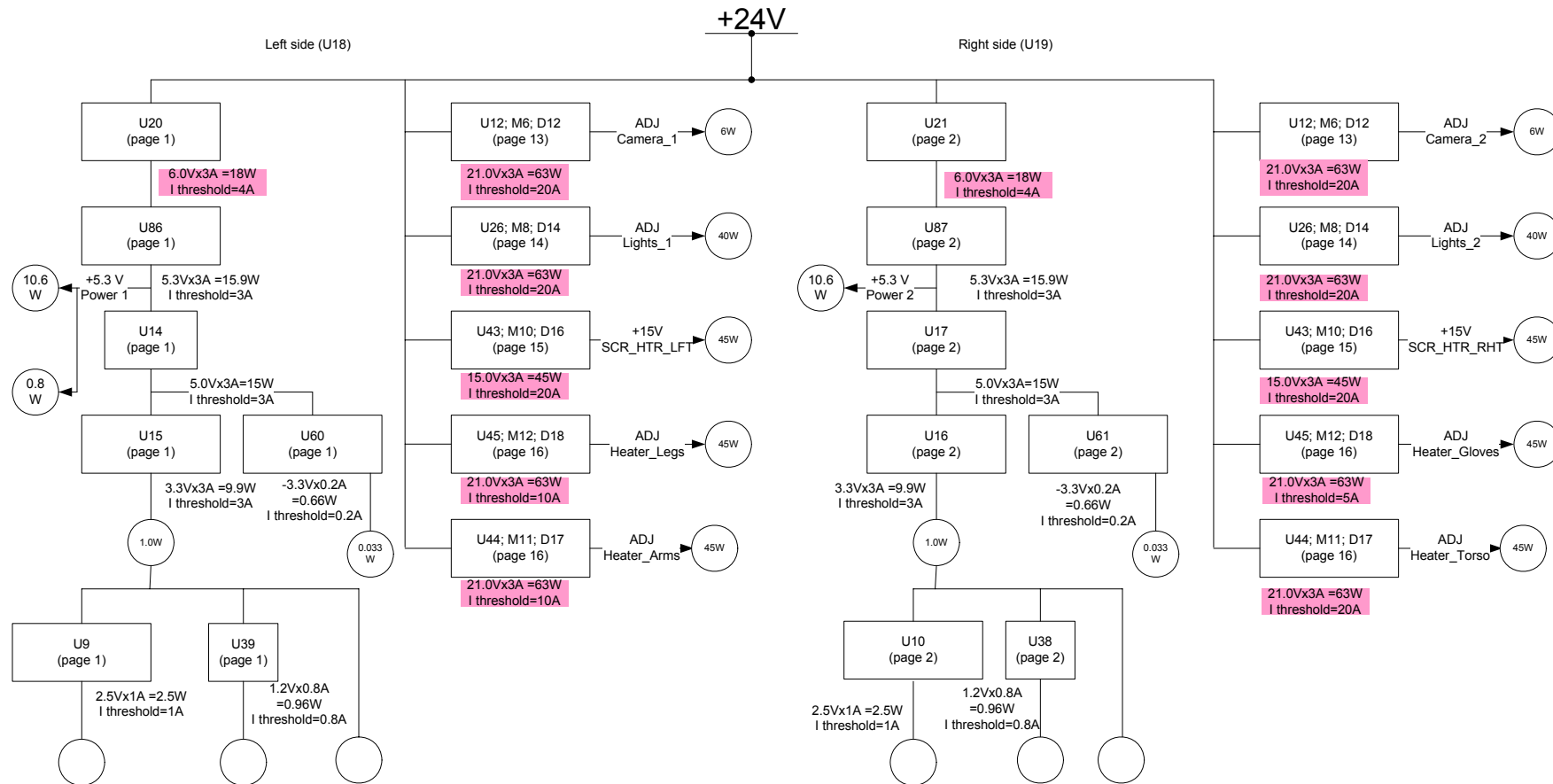

**Fig 5-1: UT power tree: the +24V sources are dual redundant using diodes. Red highlights are those that have corrective action from this review.**

## 6 POWER SOURCE CHARACTERISTICS

A full review was carried out by Dr. Sergei Pyko, Dr. Alex Deas and Marat Evtukov of the required maximum currents shown in the power supply tree and the actual level of current protection, from an examination of the circuit Revision C1.

**Table 1: Power source characteristics**

#	Ref des	Uin	Uout	IC type	Uin MAX	Inom	Imax, Amps	Current Protection Amps	Thermal protection	Reference
1	U20; U21	+12 - +24 V	+6.0V	LT1374 HV	+32	<2A	3	4	Y	Defined by MBR333 diode (LT1374-4.2A; Inductor I=6.5A)
2	U86; U87	+6.0 V	+5.3V	MIC29302	+26	<2A	3	3	Y	Power 1; Power 2 points
3	U14; U17	+5.3 V	+5.0V	MIC29302	+26	-	3	3	Y	
4	U15; U 16	+5.0 V	+3.3V	MIC29302	+26	-	3	3	Y	U15 powered PFD and sil mic in helmet
5	U9; U 10	+3.3 V	+2.5V	MIC39100 -2.5	+16	-	1	1	Y	
6	U39; U38	+3.3 V	+1.2V	LD1117D T12TR	+15	-	0.8	0.8	Y	
7	U60, U78; U61, U79	+5.0 V	-3.3V	MAX1044 LT1964	-20V	-	0.2	0.2	Y	
Heaters, Camera, Lights power										
8	U12, M6, D12	+24 V	ADJ 5-21V	LTC1624, IRF1503, MBRS330	36V	0.5A	3	20	N	Camera_1 (p.13)
9	U11, M7, D13	+24 V	ADJ 5-21V	LTC1624	36V	0.5A	3	20	N	Camera_2 (p.13)
10	U26,	+24	ADJ	LTC1624	36V	2.0A	3	20	N	Lights_1

	M8, D14	V	5-21V							(p.14)
11	U24, M7, D13	+24 V	ADJ 5-21V	LTC1624	36V	2.0A	3	20	N	Lights_2 (p.14)
12	U43, M10, D14	+24 V	+15V	LTC1624	36V	3.0A	3	20	N	Counterlung_ heater_left (p.15)
13	U42, M9, D15	+24 V	+15V	LTC1624	36V	3.0A	3	20	N	Counterlung_ heater_right (p.15)
14	U45, M12, D18	+24 V	ADJ 5-21V	LTC1624	36V	3.0A	3	10	N	Heater_Legs (p.16)
15	U44, M11, D17	+24 V	ADJ 5-21V	LTC1624	36V	3.0A	3	10	N	Heater_Arms (p.16)
16	U46, M13, D19	+24 V	ADJ 5-21V	LTC1624	36V	3.0A	3	5	N	Heater_Glov es (p.17)
17	U47, M14, D20	+24 V	ADJ 5-21V	LTC1624	36V	3.0A	3	20	N	Heater_Torso (p.17)

Note: red colour indicates sources with risk of short current damage on the circuit revision C1.

## 7 POWER ARCHITECTURE REVIEW

### 7.1 Internal UT power, BASE and PFD power supplies

These power supplies have their over-current protection set below corresponding I<sub>max</sub> margins. Under normal operation conditions maximum output current of the power supplies are significantly lower than the I<sub>max</sub> margins (up to 2A for the BASE in accumulators charging mode, <300 ma for the UT itself, 250 ma for the PFD).

The only exceptions are D24 and D8 that have direct current 3A, which is very close to the over-current protection margin. These diodes should be replaced with the parts rated at 5A continuous current.

**Action:** These power supply sources are designed correctly, except for diodes D24 and D8, which shall be replaced with higher rated components approved by the reviewers. Immediate ECO required with rework.

### 7.2 UT power sources for heaters, lamps and cameras

These power sources have maximum output current limited to 3A by MBR330 diodes. Over-current protection circuits have been set to 5-20 A (see the above table for details). This is unsafe and can destroy system in an event of output's short circuit.

**For information:** The UT design took into account that there may be very low voltage heaters: this was one format that was tested, where there are large numbers of parallel fingers on the heating element, giving a low load resistance. To use these low voltage heaters, currents of up to 20A are needed. This requires fitting the appropriate diodes and FETs: they are not fitted as standard, which gives rise to the large

discrepancy and safety issue that was identified in the above table. At the moment only high voltage (6V to 18V) heater panels are used, so the current limits and trips<sup>1</sup> should reflect this.

The suit heaters are available in two forms: one is a dumb heater that relies on the material properties to limit the maximum temperature, the second has a built in trip using voltage and current balance across the heater. The second type can produce large amounts of heat safely, in a small space: the dumb heater must have external current foldback circuits that are very close to the operating currents to prevent thermal runaway. The new limits are being set for dumb panels.

**Actions** Immediate ECO required, with rework. To prevent damage under short conditions:

1. Limit heaters current to 3A.
2. Limit lamp and camera current to 2A.

### 7.3 Engineering Change Order (ECO) Rework list

To prevent damage to power supplies in the event of output short circuit conditions the following reworks shall be done immediately, with rework to all existing units:

**Table 2: Reworks**

#	Refdes	Now installed	Replace with	Notes
1	D6, D7, D8, D24	MBRS330T3G	MBRS540T3G	To increase direct current to 5 Amps
2	D11, D12, D13, D14, D15, D16, D17, D18, D19, D20	MBRS330T3G	MBRS540T3G	To increase direct current to 5 Amps
3	R33, R34, R36, R37	RES2512 1% 0.005 $\Omega$ , 2W	RES2512 1% 0.025 $\Omega$ , 2W	To limit maximum current to 4 A
4	R204, R205	RES2512 1% 0.01 $\Omega$ , 2W	RES2512 1% 0.02 $\Omega$ , 2W	To limit maximum current to 5 A
5	R80, R81, R84	RES2512 1% 0.005 $\Omega$ , 2W	RES2512 1% 0.02 $\Omega$ , 2W	To limit maximum current to 5 A

The UT PCB will be powered from the combined umbilical, which as dual redundant supplies within it. The rework to the UT to support this shall be implemented. This divides the input 24V supply onto independent supply lines for left and right halves of the UT board: it was bridged for the underwater trials because the temporary umbilical has only one supply.

## 8 EQUIPMENT USED FOR EMPIRICAL TESTING

The equipment used for the empirical validation of the UT was:

- ◆ UT Board Serial number 106 was selected for empirical testing to validate the power systems under fault conditions, after implementation of the above ECOs.
- ◆ Time Electronics 8 Digit Precision bench computing multimeter, Model 5075, S/N 1234J04 was used for all current measurements.
- ◆ Mastec Handheld 3½ digit multimeter, Model M890G, S/N 29931139804 was used for all voltage measurements.

<sup>1</sup> A "trip" is term for an electronic cut out or automatically resetting circuit breaker.

- ◆ Astec 1.5KW 24V Switching Power Supply, Model V53-B3-B3-B3-A6-00-CE, S/N 03510001 was used as the umbilical power source.
- ◆ Cables, water drum and other minor items as indicated in the description of each test.

All equipment other than cables, water drum and minor items are in calibration, attested by a current calibration label indexed to the QA registry.

## 9 VALIDATION TESTS

All power supplies, including internal (UT's circuits) and external (lamps, heaters etc), were validated using a range of empirical tests.

Before testing started, a series of experiments/measurements with Camera-1 power supply was performed with various load values (including short circuit at maximum output voltage condition) to confirm that the correct value for the current-sense resistor is the same as the theoretical value. Short circuit tests were also performed for Camera\_2, Lights\_1, Lights\_2 and Heater\_Gloves: all other supplies are the same.

It was discovered that theoretically calculated values of current sense resistors should be slightly reduced to avoid activation of over-current protection too early (in the normal operational range). It should be taken into consideration that output characteristics of the power supplies assume current-limiting mode when their loads exceeds specific values. The power supplies switch back to voltage-stabilisation mode automatically when the load reduces, i.e. resistance of the load increases.

For every power source, tests were carried out to check the performance of the supply in eight different areas:

1. Power on/off without load, to validate supplies driving external loads are off upon power up.
2. Characterise each individual supply across the range of normal load conditions to ensure that any subsequent damage to any supply from these tests can be detected.
3. Check the effect of external loads, including shorts, on internal power supplies (within the UT, that do not drive external loads).
4. Validate that under no-load mode conditions when switching the power supplies on, there is no voltage overshoot.
5. Validate that there is no damage when powered on with the maximum load, with all supplies loaded at the same time.
6. Validate that powering on and off under a load that exceeds protection threshold does not result in damage, and over-current protection works.
7. Validate that with individual outputs shorted, and also with all outputs simultaneously short circuited to either ground or to each other, that there is no damage or and over-current protection works.
8. Validate that shorting the outputs using a saturated saline solution does not cause damage and over-current protection works under these conditions.

In addition, tests were carried out to determine the effect of a total loss of silicone oil coolant on the thermal stability of the supplies and the UT.

Note that brown out, power drop out, over-voltage and watchdog functions are tested and reported as part of FMECA Volume 5: they will not be duplicated here.

### 9.1 Status on power up

On power up, all external supplies are powered off. This was verified by empirical testing and by a check of the Verilog code.

## 9.2 Validate PSUs across the spectrum of normal load conditions

**Table 3:**

Power Source	Scr left	Scr right	Cam 1	Cam 1	Cam 1	Header Gloves	Header Arms
R sence	0.05	0.005	0.05	0.03	0.025	0.02	0.01
R load	Voltage						
No load	15.13	15.14	15.05	15.05	15.05	14.81	14.97
20	15.03	15.11	15	15.02	15.02	14.77	14.96
10	14.59	15.09	13.96	14.98	15	14.74	14.94
7.8	12.53	15.08	11.65	14.91	14.99	14.73	14.93
6.8	11.17	15.08	10.5	14.78	14.97	14.72	14.93
5.1	9.17	15.08	8.64	13.81	14.82	14.7	14.92
0	0.11		0.11	0.25	0.27	0.31	
	Current						
20	0.7515	0.7555	0.75	0.751	0.751	0.7385	0.748
10	1.459	1.509	1.396	1.498	1.5	1.474	1.494
7.8	1.60641	1.933333	1.49359	1.911538	1.921795	1.888462	1.914103
6.8	1.642647	2.217647	1.544118	2.173529	2.201471	2.164706	2.195588
5.1	1.798039	2.956863	1.694118	2.707843	2.905882	2.882353	2.92549

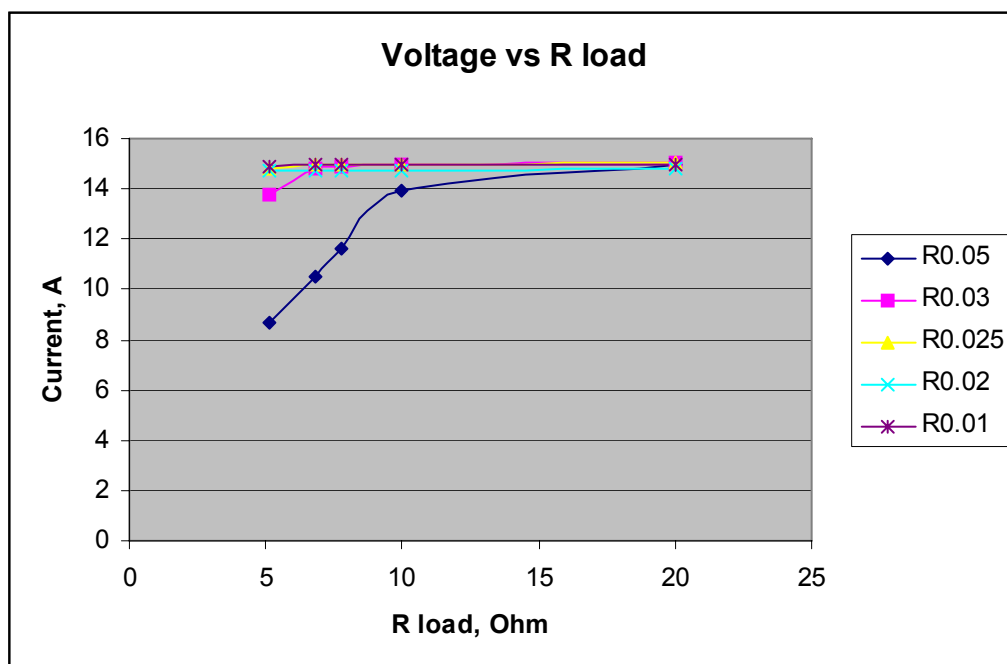

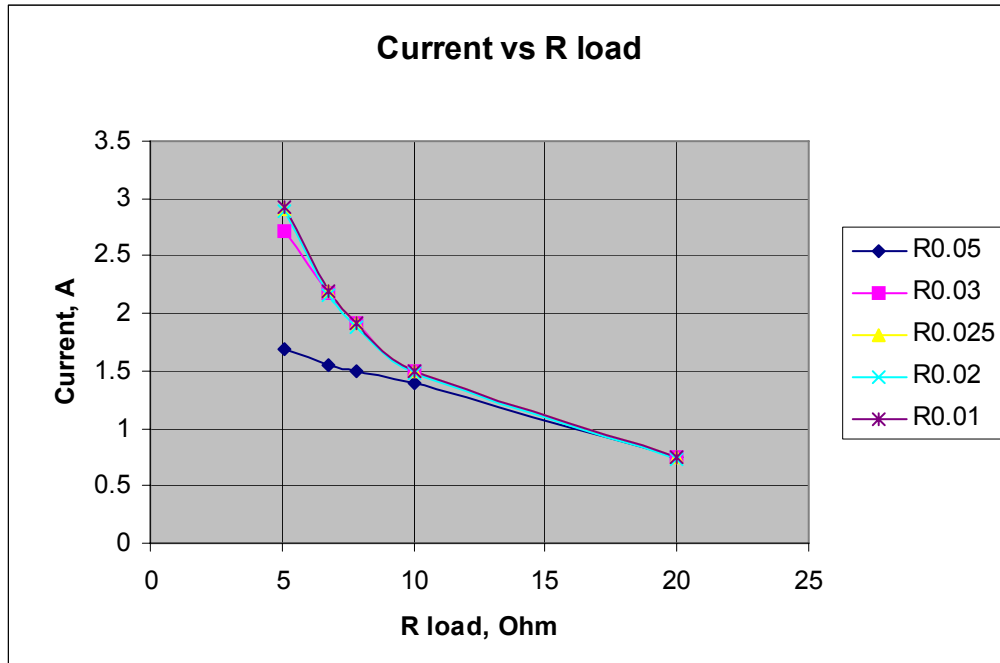

### 9.3 Absence of Overshoot

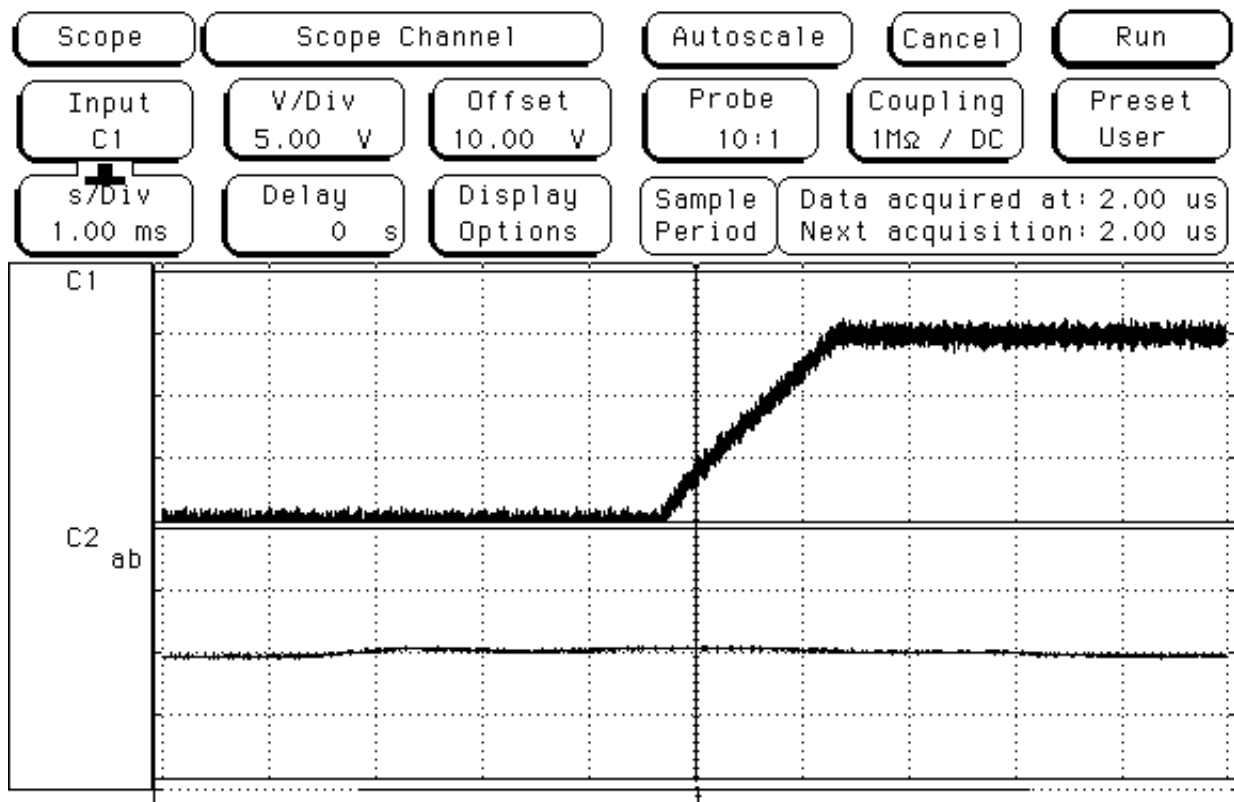

**Fig 9-1: Camera 1 source power under output voltage step change (Channel 1 only).**

No material overshoot was seen on any supply. A typical plot is shown in the figure above (for Camera 1).

## 9.4 Internal power supplies and BASE power supplies (power1, power2) validation

The internal power supplies provide regulation through to their dropout limits. They are not affected by loads on the external supplies: these are a different power supply chain.

The power supplies of this type are connected in a chain: 24V -> 6V -> 5.3V -> 5.0V ->  $\pm 3.3V$  -> 2.5V / 1.2V. During the power validation tests the power supplies' outputs were shorted one-by-one (working from the end of the chains to their start). Each short lasted 20 seconds. After releasing of each power supply source all power supplies in each chain were check to ensure they regulate normally. Results of the experiments are presented in the following tables.

**Table 4: UT 1 internal power tree tests**

#	Power source	Output Voltage	Max Current, A	Tolerate to Short circuit?	+24 V PS current (max)	Short current location	Note
1	U20	6.0V	4.2	Not checked		C136	Diode replacement required
2	U86	5.4V	3.0	Y	0.968	C133	Power 1 external line. Uout=5.38
3	U14	5.0V	3.0	Y	0.968	C110	Uout = 5.02
4	U15	3.3V	3.0	Y	0.968	C111	Uout =3.36
5	U9	2.5V	1.0	Y	0.46	C117	
6	U39	1.2V	0.8	Y	0.24	C120	
7	U60	-5.0V	0.2	Y	0.12	C253	
8	U78	-3.3V	0.2	Y	0.12	C254	

**Table 5: UT 2 internal power tree checks**

#	Power source	Output Voltage	Max Current, A	Tolerate to Short circuit?	+24 V PS add on current	Short current location	Note
1	U21	6.0V	4.2	Not checked		C140	Diode replacement required
2	U87	5.4V	3.0	Y	0.48	C138	Power 1 external line. Uout=5.38
3	U17	5.0V	3.0	Y	0.991	C114	Uout = 4.96
4	U16	3.3V	3.0	Y	0.991	C115	
5	U10	2.5V	1.0	Y	0.46	C119	
6	U38	1.2V	0.8	Y	0.24	C118	
7	U61	-5.0V	0.2	Y	0.12	C255	

8	U79	-3.3V	0.2	Y	0.12	C256	
---	-----	-------	-----	---	------	------	--

Note: With no external loads connected the UT board itself consumes 0.1A from the input +24V supply. This is a 2.4W consumption.

## 9.5 PSU validation under single supply fault conditions

All the external supplies are of the same design.

The results are shown below for Camera 1 supply, involving components U12, M6, D12 (Rev C1 Circuit Diagram Page 13).

**Table 6: Camera 1 power supply tests**

Test type	Test Description	Test result	Note
1	No load connected Voltage set =15V Power ON and power OFF	Vout=15.06V	
2	Load connected: 7.5 $\Omega$ Voltage set =15V Power ON and power OFF	Vout = 14.9 V at Rload = 20.0 $\Omega$ Vout = 13.9 V at Rload = 10.0 $\Omega$ Vout = 11.7 V at Rload = 7.8 $\Omega$	
3	Load connected: 5.0 $\Omega$ Voltage set =15V Power ON and power OFF	Vout = 8.63 V at Rload = 5.1 $\Omega$	
4	Voltage set =21V Power ON with no load, then - short output, then release output (no load).	Passed. When output was shorted, output voltage dropped down to 0V and returned back to 21.0 V when output was released	

## 9.6 Simultaneous short circuits

Power supplies with output pins located on the surfaces of the UT unit were tested for tolerance to simultaneous shortening their outputs. The power supplies chosen are: camera1 and 2, lights1 and 2, heater arms, heater legs, heater gloves, heater torso, counterlung heater left and counterlung heater right.

Since MBRS540T3G diodes required for reworks had not been delivered by the time of the experiment all the power supplies under test were configured for maximum current of 2 A. This was done by setting current sense resistors to 0.05  $\Omega$  values.

### 9.6.1 Simultaneous short circuits (power-to-ground) on all power supplies.

The following experiments were performed:

- ◆ Under no-load conditions all power supplies were set to +15V and switched on.

- ◆ One-by-one positive outputs of power supplies were connected (soldered) to ground (i.e. after first step output 1 was connected to ground, after step 2 – outputs 1 and 2 etc). After every step output voltages of not-shortened power supplies were measured.
- ◆ A dedicated experiment was done for the case when one half of the power supplies (left or right) had their outputs shorted to ground whereas the other half worked in no-load conditions.
- ◆ After being connected to ground all power supplies outputs were released (disconnected from ground) and corresponding output voltages were measured with no load and with 20 Ω load.

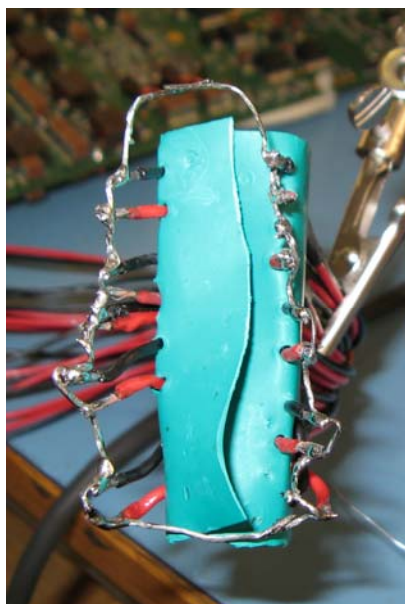

**Fig 9-2: Group short current test**

The results are tabulated in the following table:

**Table 7: Group short current test results. Values in volts**

#	Camera 1	Lights 1	Heater Arms	Heater Legs	Camera 2	Lights 2	Heater Gloves	Heater Torso	Counterlu ng Heater left	Counterlu ng heater right	Test conditions
1	15.07	15.01	14.99	15.10	14.94	14.94	14.77	14.96	15.08	15.08	No load
2	Short	14.98	14.95	15.06	14.94	15.10	14.86	14.77	15.08	15.10	
3	Short	Short	14.94	15.06	14.90	14.93	14.76	14.77	15.08	15.10	
4	Short	Short	Short	15.06	14.89	14.93	14.75	14.76	15.08	15.10	
5	Short	Short	Short	Short	14.89	14.93	14.75	14.76	15.07	15.09	
6	Short	Short	Short	Short	Short	14.92	14.74	14.75	15.07	15.09	
7	Short	Short	Short	Short	Short	Short	14.73	14.74	15.06	15.07	
8	Short	Short	Short	Short	Short	Short	Short	14.74	15.06	15.07	
9	Short	Short	Short	Short	Short	Short	Short	Short	15.05	15.07	
10	Short	Short	Short	Short	Short	Short	Short	Short	Short	15.06	
11	Short	Short	Short	Short	Short	Short	Short	Short	Short	Short	See note 2

12	15.02	14.95	14.92	15.06	Short	Short	Short	Short	Short	Short	UT 1 only, no load
13	14.89	14.95	14.99	14.85	Short	Short	Short	Short	Short	Short	UT 1 only, Rload = 20 $\Omega$
14	Short	Short	Short	Short	14.89	14.90	14.72	14.73	Short	Short	UT 2 only, no load
15	Short	Short	Short	Short	14.83	14.84	14.66	14.73	Short	Short	UT 2 only, Rload = 20 $\Omega$
16	15.05	14.98	14.96	15.08	14.91	14.94	14.76	14.76	15.09	15.10	No load
17	14.98	14.92	14.88	15.01	14.85	14.87	14.70	14.70	15.03	15.04	Rload = 20 $\Omega$

Notes:

1. Uout=15V
2. Total current for +24 V source is 0.4A

### 9.6.2 Output to output short circuit tests

Camera 2 and Lights 2 (i.e. lines Camera\_2\_Plus and Lights\_2\_Plus) were selected for the experiment. All other outputs were shorted to ground (see the following picture).

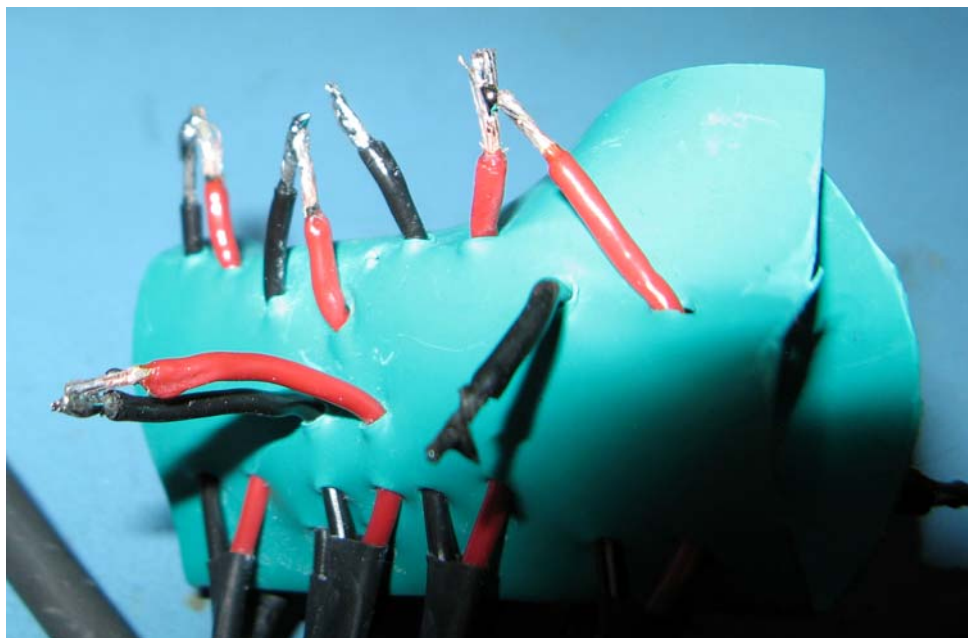

**Fig 9-3: Short circuit of two power supplies' positive outputs**

Results of this test are presented in the following table:

**Table 8: Short circuit of two power supplies' positive outputs results**

<b>Camera 2</b> <b>U =</b> <b>14.93V</b>	<b>Lights 2</b> <b>U =</b> <b>7.00V</b>	<b>No load</b> <b>V</b>	<b>Rload = 15.1Ω</b> <b>V</b>
ON	ON	14.93	14.80
ON	OFF	14.93	14.80
OFF	ON	6.99	6.95
OFF	OFF	0	0

The experiment showed that a short circuit between positive outputs of any two power supplies did not cause any malfunction that would lead to a potentially dangerous situation.

## 9.7 Salt water shorts

A saturated saline solution was mixed using water at room temperature (23C).

During the validate power supply, outputs were put into this saline solution and their voltage and current parameters were measured.

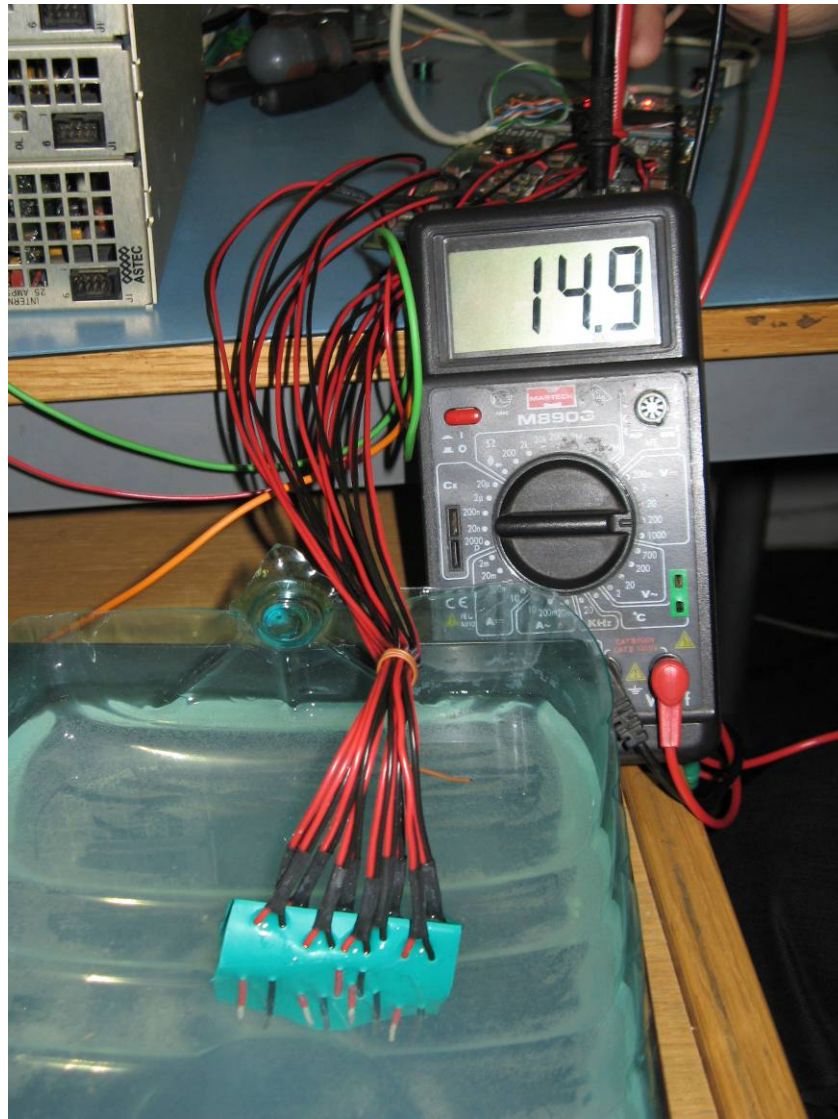

**Fig 9-4: Test of the power supply outputs plunged into salt water**

The sequence used for this experiment was:

1. Outputs of following power supplies - camera1,2, lights1,2, heater arms, heater legs, heater gloves, heater torso, counterlung heater left, counterlung heater right were wired to a former to give a maximum amount of exposed conductor (several times that of a connector), and plunged into a saturated solution of salt (NaCl) in water at a temperature of 23C.
2. Power supplies were set to +15V output voltage and switched on.
3. Actual output voltages were measured as well total consumed current form the input +24V supply.
4. The assembly was removed from the water and plunged in again when powered, and any differences from the result of that above was noted (there were none).

The results are presented in the following table:

**Table 9:**

Lights 1	Camera 1	Heater Arms	Heater Legs	Lights 2	Camera 2	Heater Gloves	Heater Torso	Counterlung Heater left	Counterlung heater right	Test condit
14.98	15.04	14.96	15.07	14.94	14.90	14.76	14.77	15.09	15.08	Uout=1 Into water
14.98	15.04	14.96	15.07	14.94	14.90	14.76	14.77	15.09	15.07	Uout=1 In the a

Total consumed current from the input +24V supply was just 40mA. That means that even being put into a salt water with all connectors open and unprotected the UT block's power supplies work properly with no potential danger of damage.

## 9.8 Worst case thermal faults

The power supplies have built in thermal protection. The purpose of this test was to determine how long the UT could operate safely in the event of a complete loss of silicone coolant.

The UT is in a custom injection moulded plastic housing, made from Kynar, with very thick walls. Thermal losses through the walls are very low. The UT relies on a large number of metal penetrators to remove the heat: these include connector shells, pressure compensating pistons and pressure sensors that are connected to the Stab plate manifold block (a large thermal mass, connected to another mass – the Stab plate itself).

When the UT is in water, the metal components remove the heat from the UT board by thermal conduction through the silicone oil inside the UT housing. There is an air cooling path from the bottom of the rebreather, past the Stab plate and out the top panel, such that even when the unit is out of the water for a long period, these external metal components are cooled.

The purpose of this test is to determine how long the unit can operate for if there is a complete loss of silicone coolant, and the air flow is blocked. This was carried out by placing the UT on a large flat surface, with temperature sensors fitted to six positions on the circuit board, covering the power supplies, optical microMUXes and the FPGA area.

### 9.8.1 Hazard level

The circuitry will fail rapidly as the temperature increases above 150C. The MTBF has been carried out using 125C as the reference temperature: the normal operating temperature is below 60C.

The switching power supply circuits all contain thermal cutouts, which should limit the temperature rise to not more than 150C, but there will still be a quiescent level of 2.4W.

The firmware switches off lights and heating pads when the rebreather is not breathed from: this should eliminate this risk, except for when the unit is in test mode that over-rides these provisions or there is a major loss of silicone oil from the UT housing.

### 9.8.2 Limits

The experiment was stopped when the highest temperature reached 90C to prevent damage to the board. The time to reach this temperature was recorded.

With no load and an ambient temperature of 23C, the highest temperature recorded on the UT was 90C after 3 hours, a rise of 0.37C per minute.

With one light channel on full power, the highest temperature recorded on the UT was 90C after 1.5 hours, a rise of 0.74C per minute.

## 9.9 Result summary

**Table 10: Test result summary**

#	Test	Result
1	Validate power on/off: that external supplies are off upon power on	Passed
2	Characterise sources across the spectrum of load conditions	Passed
3	Internal power supplies tolerate worst case conditions on external supplies, and also shorts anywhere on their power chain	Passed
4	Confirm no voltage overshoot	Passed
5	Maximum load on all supplies at the same time.	Passed
6	Power on with excessive load conditions	Passed
7	External power supplies validate for short current of all outputs	Passed
8	External power supplies validate in salt water	Passed
9	Effect of total loss of silicone oil coolant	0.37C per minute temperature rise under no load, doubling with each power supply that is on with maximum load.  This gives 90 minutes operating life under these fault conditions, with one load.

## 10 CONCLUSION

1. The review detected a number of potentially dangerous problems related to the setting of over-current protection schemes. The original Design Authority had left the power limits as standard figures because there was no confirmation at the time of what the actual maximum camera power, lighting power and heater power was. This was corrected.
2. An Engineering Change Order is issued with list of immediate reworks. The reworks have been verified to remedy all of problems detected. The reworks are just replacement of specific resistors and diodes (pin-to-pin, without any PCB alterations).
3. Experimental validation of the reworked UT board confirmed the efficacy of the suggested reword and demonstrated safe operation of the UT board and its power supplies under the worst case range of output short circuit conditions that could be expected to be encountered in the field.