

Safe PPO2 Control

Objective: To make using a rebreather no more dangerous than getting on a Boeing 737 shuttle from Edinburgh to London

July 2005

Contents

- ◆ The Problem
- ◆ How Existing Systems Control PPO2
 - Bang Bang PPO2 Controllers
 - PCM PPO2 Controllers
 - Depth Predictive PCM PPO2 Controllers
- ◆ O2 Sensor Reliability
- ◆ Putting the Cart Before the Horse
 - Injector Led PPO2 Control, Solenoid Type
 - Injector Led PPO2 Control, Needle or Pinch Valves
- ◆ Fault Tolerant Controllers
- ◆ Pricing

The Problem

- ◆ PPO2 must be within the ranges of hypoxia or CNS limits, otherwise the user dies.
- ◆ PPO2 must be controlled accurately, otherwise risk of DCS, the bends, increases.

BUT O2 Sensors have:

- ◆ a life of just a year in use
- ◆ 7 different failure modes
- ◆ sensors have a high statistical chance of failing together
- ◆ the need to be calibrated on a known gas mix each time they are used

AND the injector can

- ◆ Stick on, or off
- ◆ The control electronics can hang if the “right” component fails

If control electronics hangs, then no alarms, no handover to secondary system due to use of poor Master Slave protocol (!), PPO2 display normal, no O2 injection.

How Existing Systems Control PPO2

- ◆ Most use simple “**Bang – Bang**” controllers.
- ◆ Two companies use a **PCM Controller**.

Both Bang-Bang and PCM are very simple control systems. If assume using PPO2 sensors with a 1 year life in use then best Mean Time Between Critical Failure is 1 in 85,000 hours.

The problems are:

- ◆ Not fail safe if using a solenoid valve.
- ◆ Tolerates 0 worst case failures.
- ◆ Tolerates just 1 best case failure if using 3 O2 sensors + voting

Bang Bang PPO2 Controllers

The Bang – Bang Control Algorithm is:

```
if (PPO2 <= Set_Point - Low_Margin) then
  do { Inject_O2() }
  until (PPO2 >= Set_Point + High_Margin)
```

Difference between Low_Margin and High_Margin provides hysteresis to prevent oscillation.
Amount of hysteresis needed depends on the time constant of sensors, gas mix, gas transit time.

Failure points:

1. Processor hangs due to failure of clock components, or a power disturbance and failure of brownout circuit, or any failure in software and watchdog circuit fails.
2. EMI: Often low level O2 sensor signals are routed up unscreened cable
3. More than 1 sensor fails in a 3 sensor system
4. Any of the injector drive components or wiring fails
5. Injector sticks off or on, e.g. if the intermediate pressure is too high
6. Power fails

Bang Bang PPO2 Controllers

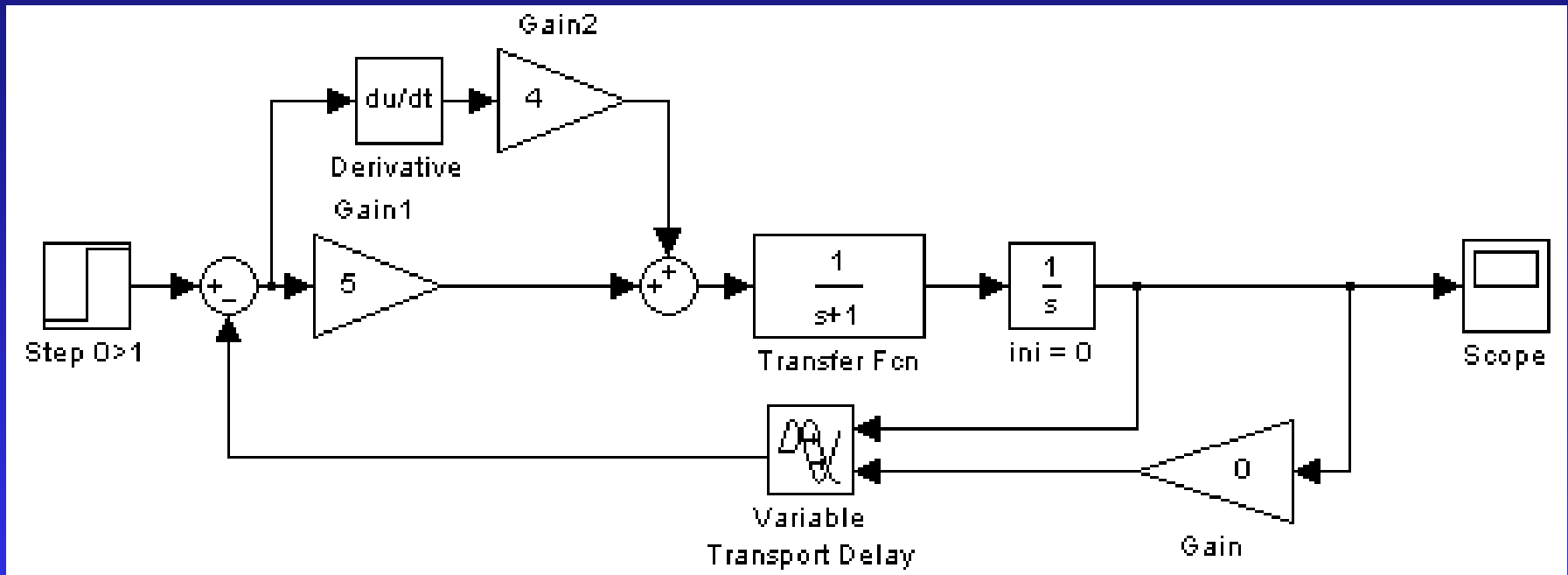

This is what the Bang-Bang controller looks like in system terms (Simulink)
All depends on the transport delay: the time between injecting and seeing an output from the O2 sensors

Bang Bang Controllers

A full scale step

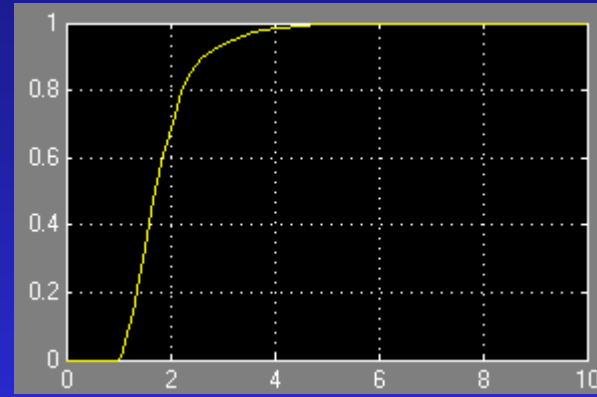
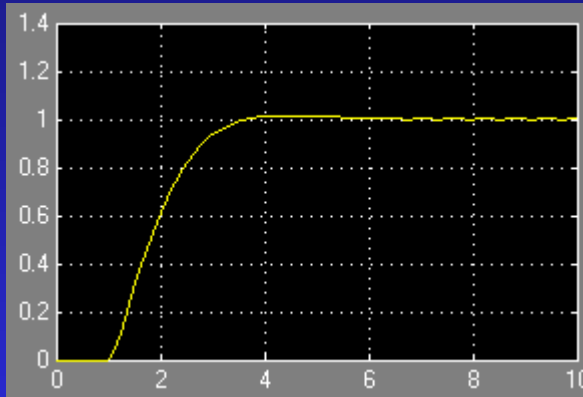

Reduce gain

A Step of 5 to 6

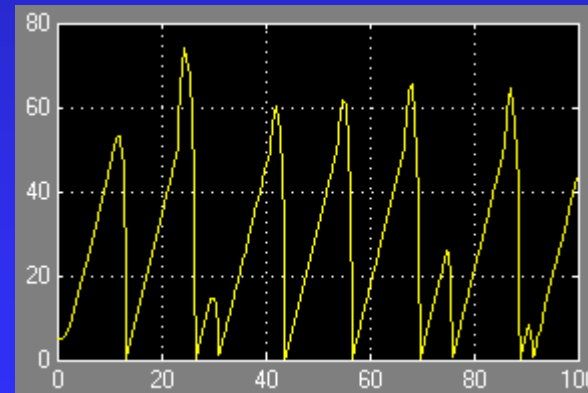
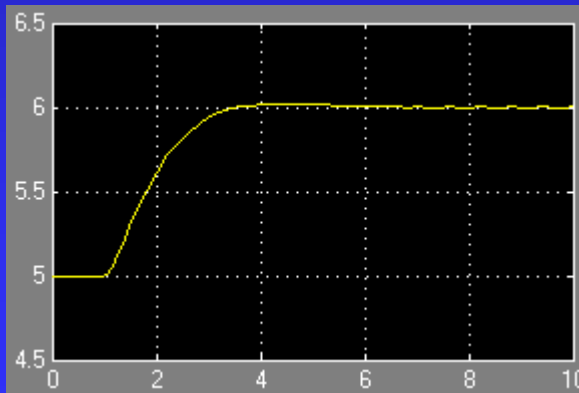

Gain 5, Transport
Delay 0.2.
Y scale x1000
No hysteresis

PPO2 levels for 4 different transport delays and gain settings

PCM PPO2 Controllers

PCM is Pulse Code Modulation.

If a Bang-Bang controller will switch the injector on for 6 seconds in one minute, a PCM controller might send 12 0.5 second pulses of O₂.

The result is a much more even PPO₂ level.

The PCM Control Algorithm is:

```
While (always) {  
    Call_Bang_Bang_Controller() /* For start up */  
    Tm = How_long_the_O2_injector_was_on_during_the_last_minute()  
    Inject_this_number_of_pulses_evenly_during_a_minute(Tm/0.5)  
}
```

Failure points: Same as for Bang Bang.

PCM Prediction with Depth Changes

- ◆ PCM controllers normally include predictive injection for depth changes
- ◆ This is very simple. Say a user is moving from 60m to 30m at 30m per min, their PPO2 will reduce by 33%. If during cal putting the O2 injector on for 2 secs caused an increase in loop pressure of 0.1bar, and PPO2 is set to 1.0, then system needs to inject for 20 seconds to keep PPO2 constant. Therefore, add this pressure difference time to T_m .
- ◆ Bang-Bang controller still needed for startup and after flushes
- ◆ The full PCM algorithm with predictive depth was published by Deep Life staff in 2000 as a "Method of using a Solenoid Valve to Approximate Behaviour of a Stepper Motor Controlled Valve in a Rebreather"

The O2 Sensor Problem

- ◆ O2 sensors are galvanic (they act like a battery, giving a voltage proportional to PPO2)
- ◆ They have a short life, and fail in 7 different ways.
- ◆ Their life is so short, there is a high probability that 2 sensors can fail in one dive
- ◆ Non-galvanic parametric O2 sensors are available, but require temperatures of around 300C to operate.
- ◆ Lots of work around the world to find a room temp parametric sensor
- ◆ Alternative methods such as mass spectrometry, are too power hungry and bulky

Failure Modes:

- ◆ Worst failure mode is the Ceiling Mode, where a sensor develops a maximum voltage it will generate.
 - When this happens, PPO2 controller injects O2 thinking PPO2 is low, but it can be off the scale.
- ◆ Broken contacts, Charge Storage (output drops very quickly after calibration), shorts, bubbles in electrolyte, drooping output, loss of sensitivity, are other modes

Putting the Cart before the Horse

- ◆ At the moment, O2 sensor readings drive the injector
- ◆ Only feedback is O2 sensor readings
- ◆ This is not fault tolerant
- ◆ What should happen is injector injects a known amount of gas, and O2 sensors check this has happened.
- ◆ Result is tolerance to any O2 sensor fault, or injector fault, and much better PPO2 control

Injector Led O2 Injection

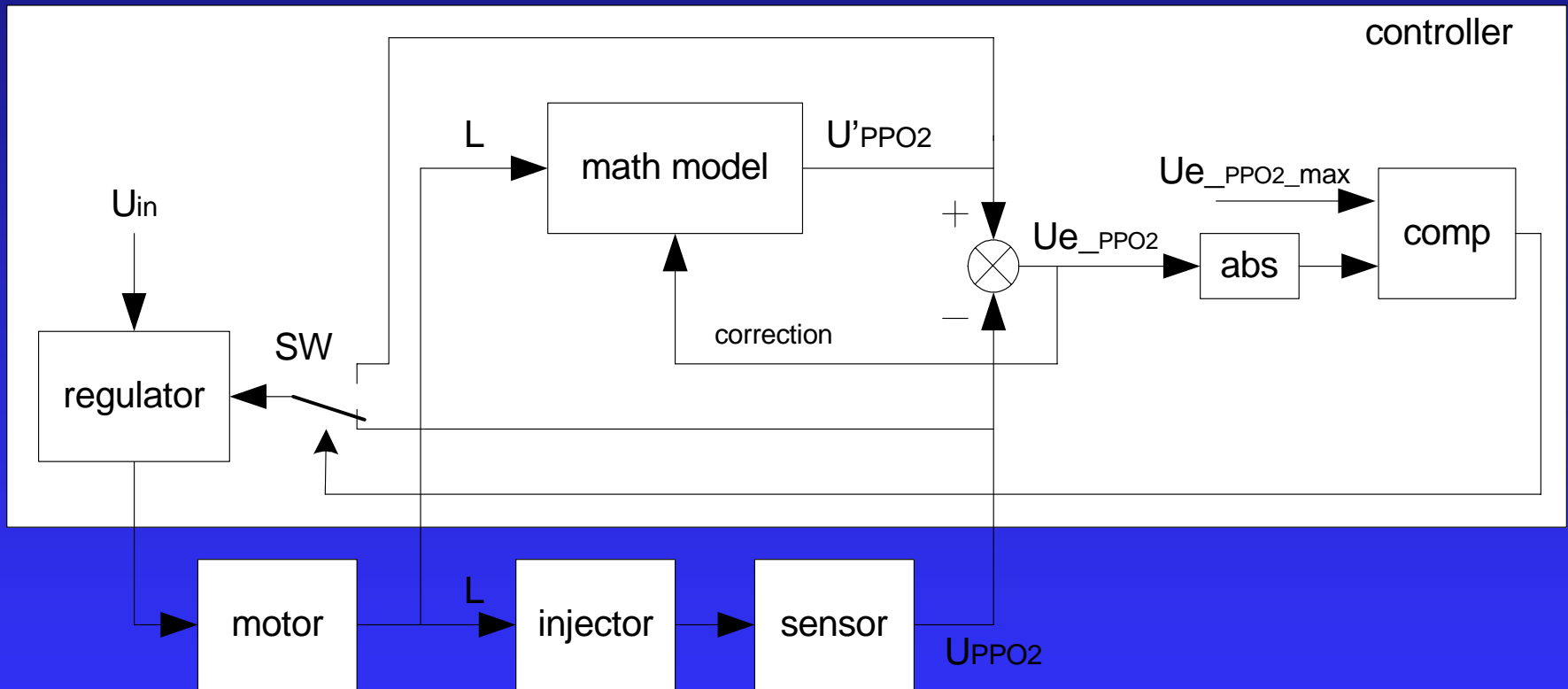

Block diagram of a fault tolerant PPO2 injector

Injector Led O2 Injection

Provides optimum response time without oscillation

And optimum PPO2 control

Even PPO2 +/- 0.001 can be achieved

Even tolerates all O2 sensors failing

Detects accurately which O2 sensor has failed, and how

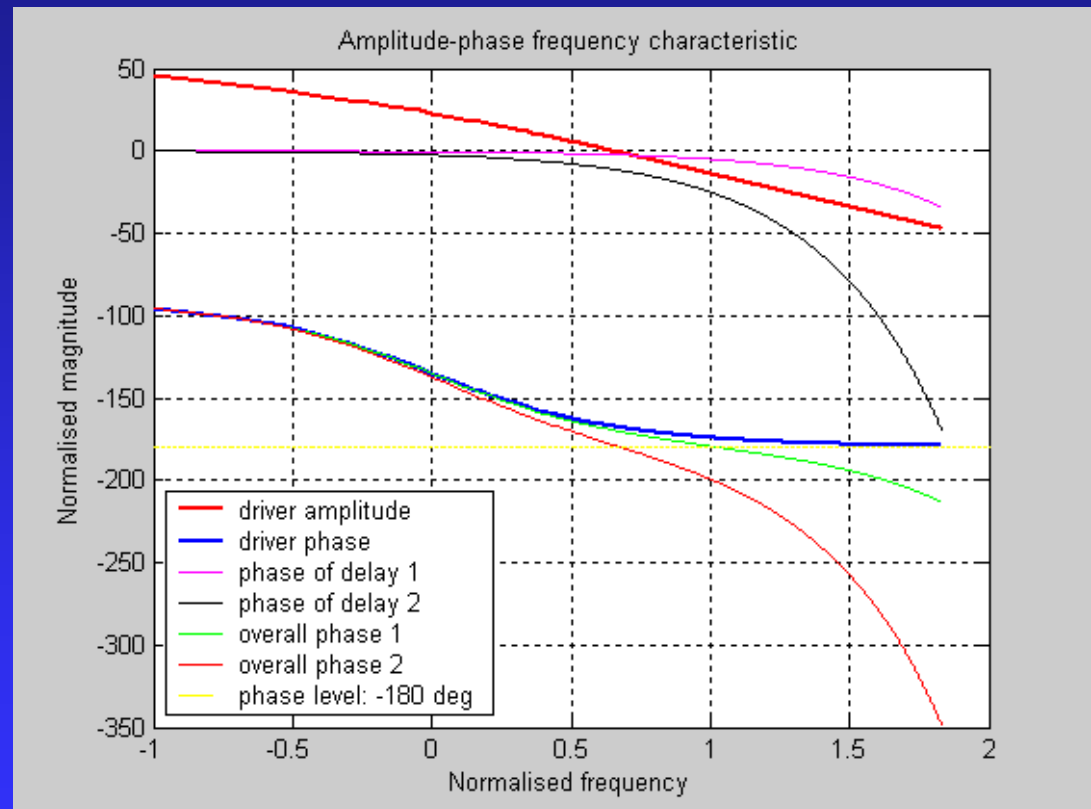

When using variable injectors

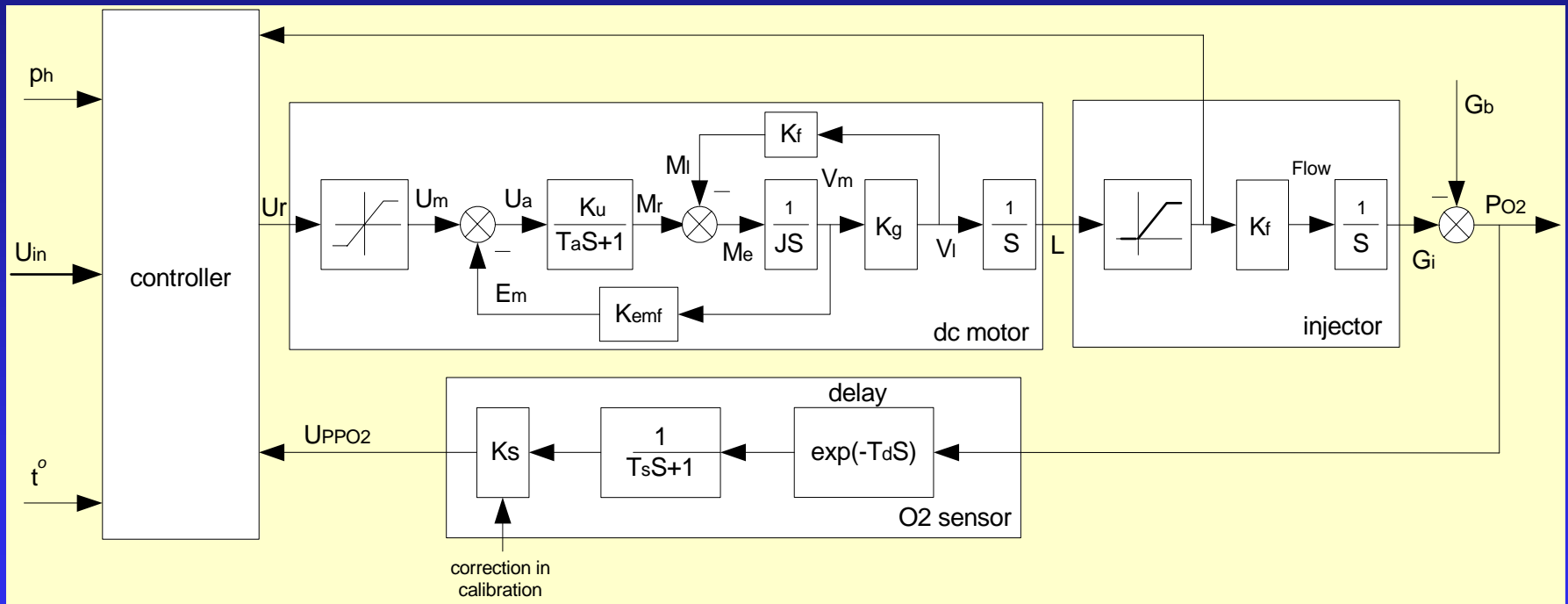

Variable injectors have a nice fail safe attribute: they can be made to inject O₂ even when power is lost.

Control system for a needle valve injector shown above. Note injection is not based on O₂ sensor readings, so should not infringe 3rd party patents.

Injector Led O2 Injection

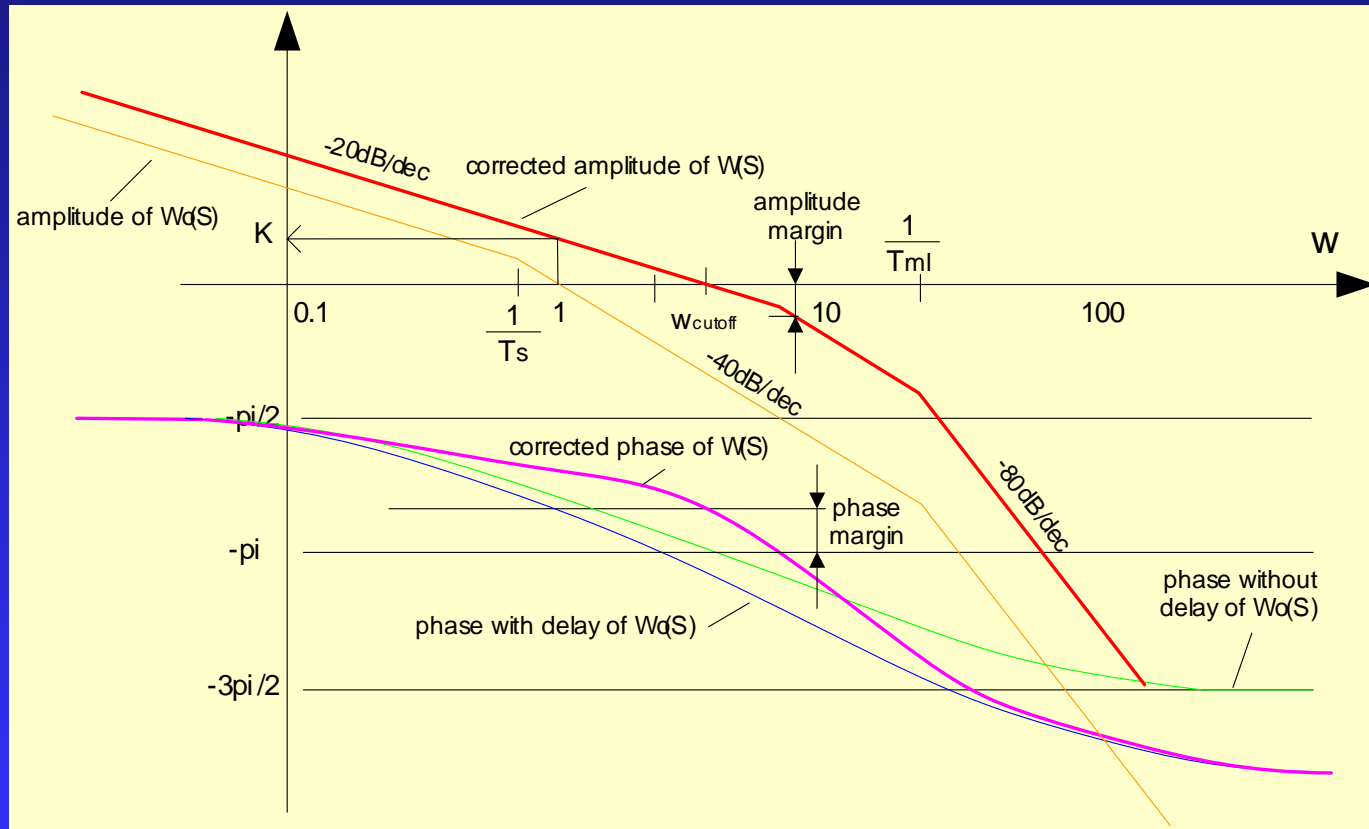

This is the phase control curve that is achieved with variable injectors
Compare with the earlier graph for a solenoid type injector.

Fault Tolerant Controllers

- ◆ Tolerates multiple random faults, and 2 worst case
- ◆ Uses Microcontroller and State Machine in FPGA (ie, two implementations using different technology)
- ◆ Includes watch dogs, brown out circuits, unused locations contain recover code and other dependable system design methods
- ◆ Full self test using JTAG
- ◆ Full FMECA Report, to component level
- ◆ 1 billion hours between Mean Time To Critical Failure of PPO2 control system if using Injector Led control

Availability of Technology

Deep Life have a fixed price scheme for PPO2 controllers.

Package includes all production tooling (pcbs, SMT, mechanical, LCD), and 2 samples, designed either for your package or includes a package design.

Lead time is 1 week + pcb layout lead time, plus 8 weeks for build and certification. Various other companies offer Bang-Bang controllers.

A Bang-Bang PPO2 Controller	Prices on request
A PCM Controller with Predictive Depth	
A Safe PPO2 Controller with optimal control of PPO2	
Fault tolerant Handset, with text display, working with controller.	
Fault tolerant Handset with custom LCD display working with controller	
Full production management (of subcontractors), including all tooling, purchasing, scheduling, inspections, QA	