

1

2

3

4

F

F

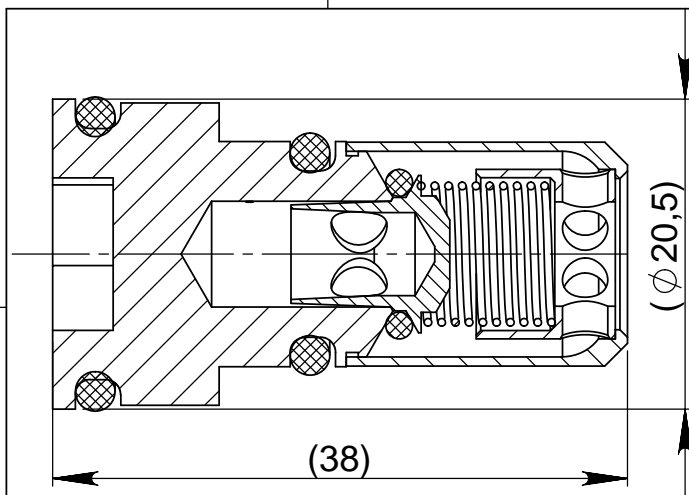

Item N	Title	Part N	Qty
183a	Valve Shell	ORT6126	1
183b	Valve Bush	ORT6127	1
183c	Valve Disk	ORT6128	1
183d	Spring Support	ORT6129	1
538	O-Ring BS011		1
548	O-Ring BS111		1
551	O-Ring BS114		1
761a	Spring	LP 020F 05 S316	1

E

E

D

D

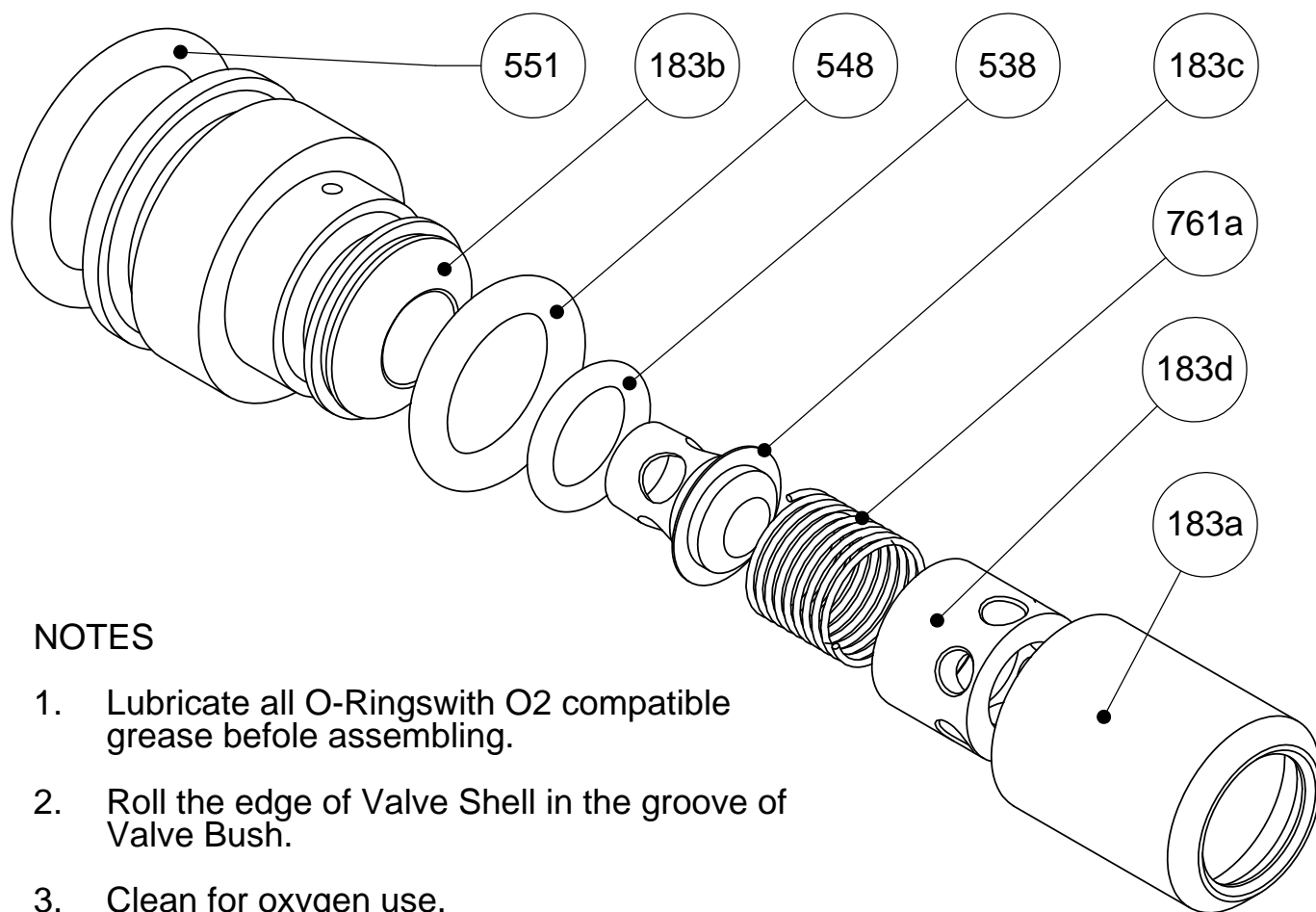

C

C

NOTES

1. Lubricate all O-Rings with O2 compatible grease before assembling.
2. Roll the edge of Valve Shell in the groove of Valve Bush.
3. Clean for oxygen use.

B

B

Units of measurement	mm, UNLESS OTHERWISE STATED	Mass
Material		
Quantity	See BOM	
Tolerances	UNLESS OTHERWISE STATED TOLERANCES: H12, h12, ±IT12/2; ANGLE - ±30°	
Surface roughness	12,5µm MAX ON ALL MACHINED SURFACES UNLESS OTHERWISE STATED	
Surface treatment		

A

A

Format ISO A4	Designed by A.Kudriashov	Change by	Approved by - date	Filename ORT6125A3	Date 07.12.09	Scale 1:1
Projection 	DEEP LIFE LTD Strictly commercial-in-Confidence copyright (c) 2009. Copying prohibited except as provided for under written contract with Deep Life Ltd.			Title/name ASSY OF CHECK VALVE		
Drawing number ORT6125				Edition A3	Sheet(s) 1(1)	

1

4